



INSTRUCTION MANUAL

XMP-302

Manual Pick and Place System with Dispenser for SMT Low Volume Assembly

P/N X-DOC129
04-Dec-02
Rev. A

650 Scranton Pocono Hwy
Covington Twp., Pa 18444, USA
Tel: (570) 842-2812 Fax: (570) 842-4290
E-Mail: bokar@bomir.com
www.bokar.com, www.SMT-tool.com,
www.ESDmeters.com, www.SMTreballing.net
www.Assembly-SMT.com, www.No-Stat.com



XMP-302 Manual Pick and Place System with Dispenser

TABLE OF CONTENTS

	PAGE
I. INTRODUCTION	2
II. SAFETY	3
III. PACKAGING	4
IV. UNPACKING AND ASSEMBLY OF THE SYSTEM	5
V. SET-UP AND INSTALLATION	7
VI. APPLICATION	8
VII. MAINTENANCE AND ADJUSTMENTS	10
VIII. TROUBLESHOOTING	11
IX. OPTIONAL EQUIPMENT	12
X. SPARE PARTS LIST FOR XMP-300 SERIES	16

I. INTRODUCTION



FIG 1. VIEW OF THE SYSTEM

XMP-302 Manual Pick and Place System with Dispenser for SMT Low Volume Assembly

XMP-302 Manual Pick and Place Systems with Dispenser

XMP-302 Pick, Paste and Place System was designed to allow the user to conveniently control the placement of the SMT components and the deposition of the solder paste on printed circuit boards. It allows the board to be placed close to the operator and an exchange of feeders for a second, optional bulk component tray loader. It comes from the factory equipped with the feeder base, six feeders, one XL-6/5D tray loader (with 6 single compartment and five, 2 compartment loose component trays) and XNS-1 needle/cup set.

II. SAFETY

The purpose of this "SAFETY" section is to inform the users of the heading guidelines used in this manual to indicate special Notes, Cautions, Warnings or Dangers. Also included are precautions, which must be observed when operating or servicing this product.

These "NOTES", "CAUTIONS", "WARNINGS" and "DANGERS" are inserted in this manual whenever deemed necessary. They appear in a blocked off form with outline and a shaded background to highlight the information as shown below.

NOTE
XX

NOTE

Used to indicate a statement of company recommendation or policy. The message may relate directly or indirectly to the safety of personnel or protection of property. NOTE is not associated directly with a hazard or hazardous situation and is not used in place of "CAUTION", "WARNING" or "DANGER".

CAUTION

Used to indicate a hazardous situation, which may result in minor or moderate injury. May also be used to alert personnel to conditions, procedures and practices which, if not observed, could result in damage to or destruction of the product or other equipment.

WARNING

Used to define additional information, that if not closely followed may result in serious damage to equipment and represent a potential for serious personnel injury.

DANGER

Defines additional information, that if not closely followed may result in severe personnel injury or death. Danger is not used for property damage unless personal injury risk is present.

PRECAUTIONS

The following are general safety precautions, which personnel must understand and follow when using or servicing this product. These precautions may or may not be included elsewhere in this manual.

CAUTIONS

1. Utilize all standard electrical safety precautions when using this or any other electrical equipment.
2. Always use this system in a well-ventilated area. A fume extraction system (such as those available from X-KAR) is highly recommended to protect personnel from solder flux fumes.

XMP-302 Manual Pick and Place Systems with Dispenser

3. Exercise proper precautions when using chemicals (e.g., solder paste). Refer to the Material Safety Data Sheet (MSDS) supplied with each chemical and adhere to all safety precautions recommended by the manufacturer.

DANGER

POTENTIAL SHOCK HAZARD – All repairs made on this product should be performed by a qualified service personnel only. Line voltage parts will be exposed when equipment is disassembled. Service personnel must avoid contact with these parts when troubleshooting.

NOTES

To insure continued peak performance, use genuine X-KAR replacement parts.

III. PACKAGING

The packaging of the XMP-302 assembly system has been carefully designed to ensure maximum protection during shipping. However, no packaging can guarantee 100% protection and damage may occur through rough handling by the carrier. Please ensure that any claims for shipping damage are reported to the carrier and to BOKAR Int. promptly.

The XMP-302 has been designed with a detachable base, which allows the system to be more manageable for packaging and shipping. Your system should include two boxes: one box contains the base; the second box contains the separate subsystems to be assembled during installation. Each box contains protective packaging materials to ensure the safe arrival of your new Pick and Place/Dispenser System.

The contents of the rectangular box are as follows:

1. XMP-CC2 Control Console Assembly
2. XZ-A302 Pick and Place/Dispense Arm Assembly
3. Six feeders (3 pcs of XPT-8, one XPT-12, one XPT-16 and one XPT-24)
4. Arm Rest Assembly
5. XNS-1 Needle/Cup Set
6. Power Cord
7. Manual

Additionally each XMP-302 System contains:

8. XDHA-1 Dispensing Head Assembly
9. XZ-SMA1 Syringe mounting hardware
10. XFS-1 Foot Switch
11. XDL-1 Compressed Air (Dispenser) connecting hose (with fitting to connect to the console)

The contents of the square flat box are as follows:

12. XMP-300 Series Base Assembly with Board Holder
13. Feeder/Optional Tray Assembly Base
14. Loose Component Tray Assembly
15. ESD grounding wire

- 16. AML-301A Wrist strap with coiled cord
- 17. Assembly/Installation Instruction Sheet
- 18. Metric Tool Kit

Please refer to the diagrams in the back of the manual to help identify the above listed parts.

IV. UNPACKING AND ASSEMBLY OF THE SYSTEM

Prior to use of the system, please check if the system is complete. Should you notice that any items are missing, please notify us, giving the details of model number, voltage, date of purchase, where purchased and what is missing. Missing items must be reported within 7 days from the date of purchase.

WARNING
When unpacking, please be careful and read the manual prior to turning the system "ON". Please check that the voltage of the System corresponds with the voltage of your available supply. Connection to incorrect voltage supply may cause damage to the System!

- A. During unpacking, please check to ensure that the system is complete. Should any items be missing, please notify us, giving details of model number, voltage and serial number.
- B. The System Base should be unpacked first and set-up on the table with the Board Holder facing the system assembler.
- C. After opening the rectangular box, please remove all small boxes and system components. The largest inside box contains the Control Console. The XMP System Console should be lifted carefully. Each side panel of the Console has on the bottom 2 mounting holes. The console has to be placed carefully (Controls facing the assembler) on 4 corresponding pins protruding upwards at the back of the System Base. Once the Console is set properly, please secure it in place by tightening 2 set screws (one of each on the front of each side panels). The appropriate hex key can be found in the Tool Kit supplied with the unit. Connect banana plug of the Arm Assembly grounding wire (located at the back of the Control Console) to the corresponding socket in the Base.
- D. Remove carefully the Arm Assembly from its separate box. The Placement Head is spring-loaded and requires delicate handling until assembled into the system. Remove temporarily the stop screw at the end of the Arm Assembly to allow installation. Feed the connectors and vacuum and dispenser hose assembly of the Placement Arm below the front panel, so that the vacuum line, dispenser hose and aluminum extrusion of the Placement Arm Assembly pass between the roller wheels of the carriage. Re install the stop screw at the end of the Arm Assembly. This will prevent the Arm from falling out during full movement forward in X-axis. Connect the black conductive tubing from the Placement Arm Assembly to the fitting marked "Vacuum Pump" on the back panel of the Control Console. Also, connect the electrical

XMP-302 Manual Pick and Place Systems with Dispenser

connector to the appropriate socket next to the vacuum fitting.

Connect the clear tubing connector of the dispensing line to the fitting marked “ Dispenser” on the back panel of the Console.

Loosen the Carriage Blocking Screw located under the carriage on the right hand side so that the arm carriage is free to travel. The Arm Assembly should move freely across the width of the machine with a minimum of effort.

Check to see that the movement in both X and Y-axes is smooth and friction free. If the X and Y movement is either tight or exhibits excessive play, then the carriage may need adjustment (see Section V, “ Carriage Adjustment”).

- E. Attach Feeder Base to the left bracket of the Board Holder. (Remove 4 screws (2 of each on each end of the bracket). Place the bracket on the base to match the holes in the bracket and re-install the screws. Use the corresponding hex key supplied with the Tool Kit XHKS-2.
- F. Connect Foot Switch plug to the socket marked “ Foot Switch” on the back panel of the Console.
- G. Attach Dispensing Syringe bracket to the Head of the Arm Assembly, place the syringe in the bracket and secure it gently. Connect the small piece of dispenser tubing with the Dispensing Head to the fitting (pneumatic quick-connect) at the side of the Arm Assembly. The Dispensing Head will twist lock on the top of any standard 10CC syringe. Attach the Dispensing Head to the syringe.
- H. Install Loose Component Tray on the supports behind the Board Holder. Connect the Tray Assembly grounding cord to the corresponding 10mm stud on the Base Assembly. Prior to installing the Loose Component Trays, the conductive trays must be checked for proper assembly into the aluminum base. Each conductive tray has two locating lugs; these must secure firmly into the aluminum base. Note that the flat surface of the component tray is provided as that adhesive marking labels can be affixed to the trays as an assembly aid. Further, this surface can be used to set down parts already picked, should they require any subsequent centering.
The complete Component Tray assembly can be installed at the back of the System or on the left side of the System (in place of the feeders).
- I. Install the feeders onto the feeder base. The front of the feeder fits into the slot in the Feeder Base right bracket. It needs to be pushed forward gently, placed into the slot in the left bracket of the Feeder Base and released. The spring loading mechanism will hold the feeder in place.
- J. Place the Arm Rest Assembly on the Base on the right hand side of the System. The Arm Rest should fit over the Board Holder and move freely on the rollers from the left to the right side of the Board Holder. Connect banana plug of the Armrest grounding wire to the corresponding banana socket in the Board Holder right bracket.

Now Your XMP-302 System is assembled and ready to be placed in the work location for final Set-up and Installation.

V. SET-UP AND INSTALLATION

CAUTION
<p>Please check that the voltage of the System corresponds with the voltage of the supply available. Voltage is specified next to the power inlet located on the right hand side of the back panel of the System.</p> <p>The System requires an AC line rated at 0.5 Amp (220/240V) or 1.0 Amp (110/115V). The system has its own fuse. Connection to incorrect voltage supply may cause damage to the System.</p>

1. The System should be located on a rigid and stable work surface. Please note that the back of the Arm Assembly protrudes beyond the back of the base panel of the unit and requires additional space.
2. Connect ESD grounding wire (AS3-B) to the grounding stud on the System Base. You can choose the stud located on the left sidewall of the Base (for the operators who wear the wrist straps on the left wrist) or the stud located next to Loose Component Tray grounding point (for the operators who wear wrist straps on the right wrist). Connect the other side of the grounding point to the ESD ground (Standard electrical ground is often used as ESD Ground).
3. The Nozzle Kit XNS-1, provided with the System includes three different nozzles for a variety of applications. The nozzle dimensions are gauge 20, 18 and 14 and ½” each. Also included are 4 suction cups of different diameters to be fitted to the two larger diameter nozzles for heavier components. The smallest nozzle is for use with discrete components, which are small. Choose the appropriate for your application nozzle and install it. The nozzles are a friction fit onto the vacuum pipette of the Placement Arm Assembly.
4. The System can now be connected to the AC supply and to an air supply providing at least 70 psi and 1.0 SCFM. Use the enclosed connecting hose to attach to the filter of compressed air source.
Connect the power cable to the socket located on the back of the Control Console and plug it into the AC supply. Load the parts into the trays, install rolls of parts on the feeders, place the PCB in the holder, set the Controls to desired positions and you are ready to place or dispense.

VI. APPLICATION

The XMP-300 series have been primarily designed for low-volume SMT assembly. Typical applications include Low Volume Assembly, prototyping, pre-production, production evaluation, repair and rework. Further applications can be found in conjunction with fully automatic pick and place machines for relocation of displaced components.

The XMP-302 Model has detachable Dispensing Head which allows for independent use of Dispensing section as an independent, hand held Fluid Dispenser. (Optional XDS-1 Syringe Stand and connecting Line is needed to use this Option).

INSTALLING REEL ON THE FEEDER

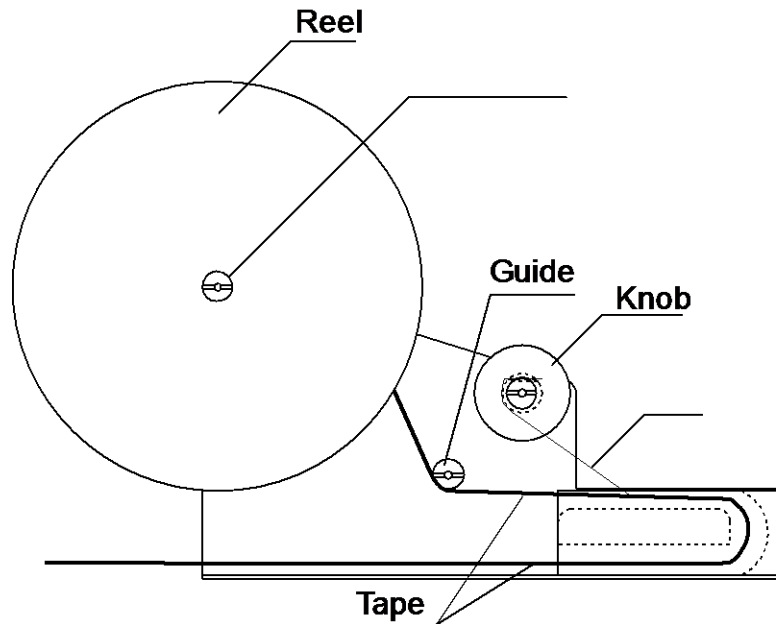

Place the reel on the reel holder. Load the tape by placing it under the guide. The transparent film that holds the component in the tape must be peeled off and fed through the slot on the knob. The empty tape will continue and feed back under the reel as shown.

A. PICK AND PLACE OPERATION

1. Connect the unit to the AC supply. The on/off switch, which is located on the front panel, on the right hand side of the Control Console (See Fig.1). Switch will light up. With the appropriate nozzle fitted, place the nozzle above the component to be lifted and lower the spring-loaded head assembly of the Placement Arm by pulling down gently on the Operation Knob. The vacuum pipette will travel upwards within the head assembly and will toggle the switch controlling the valve, which switches on and off the vacuum to the nozzle. Each time the pipette is lowered the vacuum toggles. Vacuum Indicator illuminates while the vacuum is on.
2. Components will predominantly be assembled onto boards and substrates, which have been prepared with solder paste. Caution should be exercised to avoid solder paste entering the nozzle and reducing the inside diameter or completely blocking the nozzle. An air filter is

XMP-302 Manual Pick and Place Systems with Dispenser

situated inside the Control Console as a safety feature to prevent any possibility of solder paste entering the solenoid valve. If solder paste does enter the needle, it should be manually cleaned out.

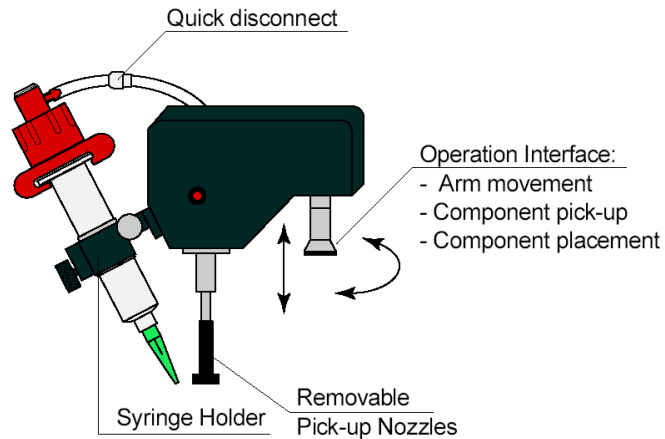

B. DISPENSER OPERATION

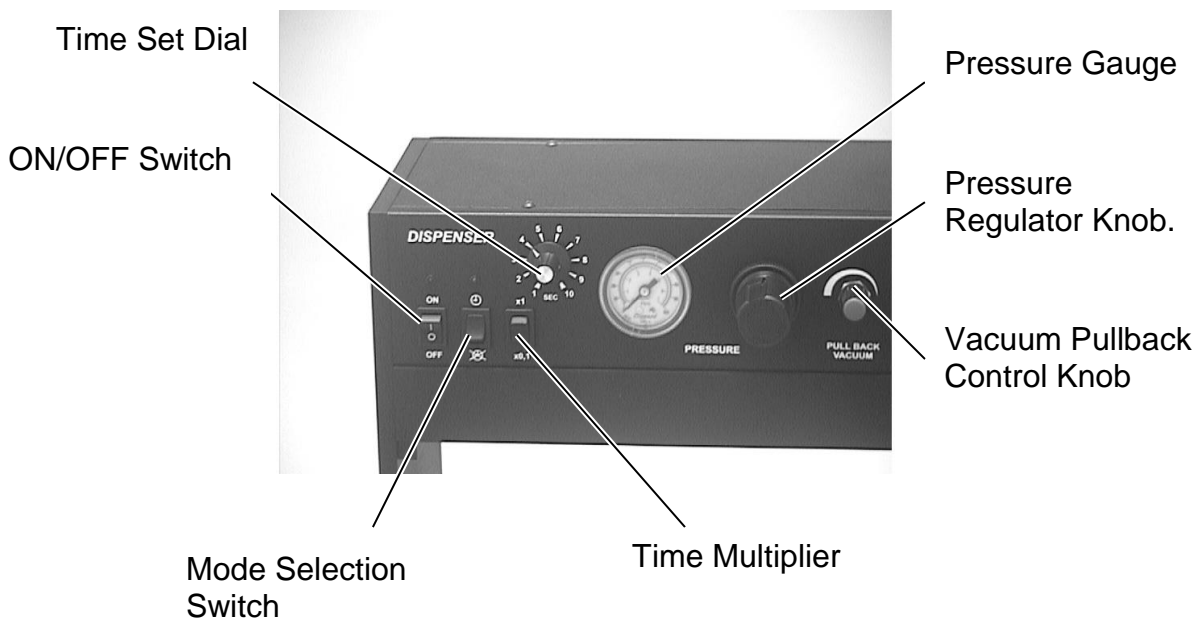

Photo 2

1. The dispenser section of the XMP-300 has its own "ON-OFF" switch.
2. Adjust the air pressure using the pressure regulator knob, while watching the pressure gauge. Typical dispensing pressure for solder paste is from 1.4 kg/cm² 3.5kg/cm².
3. The " Vacuum Pullback Control Knob" is used to control the amount of vacuum supplied to the dispense tube, to keep paste fluids from dripping out of the syringe after being dispensed.

XMP-302 Manual Pick and Place Systems with Dispenser

4. The dispenser system of XMP-300 features 2 separate dispenses modes: Manual Mode and Time Mode. The switch controls these 2 modes. The mode indicator shows your selection.
5. The XMP-300 has a detachable dispensing head assembly, which allows for independent use of dispensing section as an independent hand held dispenser.
6. For effective operation, set “Time mode” and dispense on areas, which require the same amount of paste. After that, change to the “Manual mode” and do on the other areas, which require different amounts.

A. Operation of the Dispense Modes

1. Manual Mode

If setting the mode selection switch down, it will be the manual mode. The “Manual mode” is used when there are different size areas that require different amounts of solder paste. In this mode, the LXM-300 dispenser will dispense for as long as the foot pedal is pushed. When the pedal is released, the dispensing will stop.

2. Timed Mode

You can select the Timed Mode by setting the mode selection switch up. The “Time mode” is used when solder paste dots are to be the same. Once in the timed mode, you can select the dispensing time by using the dial to select the time. The timed mode provides the operator with repeatable amounts regardless of the length of the time the foot switch is pushed. You will have ‘one shot’ for each push of the foot switch. You can use multiplication of time by a factor of 10 by changing the position of the time multiplier.

Recommendation:

Practice dispensing with each mode to become familiar with all controls prior to starting any production job.

VII. MAINTENANCE AND ADJUSTMENTS

- A. Regular cleaning of the System will ensure optimum System life and trouble-free operation. The square extrusion of the Placement Arm should be kept clean and free of any solder paste contamination. All anodized aluminum surfaces can readily be cleaned with proprietary solvent cleaner.
- B. Should the Arm Assembly exhibit signs of excessive play, which will manifest itself as a rocking or titling of the head assembly, there are two adjustments available for elimination. It should first be determined whether the source of play is in the roller wheels guiding the rectangular arm extrusion or whether the play stems from excess tolerance in the carriage wheel adjustment. This can be determined by gently rocking the head assembly and observing whether the carriage remains stationary or also exhibits a rocking movement. Both the X and Y axes movement is accomplished by the arrangement of the roller wheels on the top and bottom of a rectangular arrangement of the roller wheels. The roller wheels should be adjusted so that minimum effort is required to achieve movement. It should be possible to achieve a setting so that a small “flick” provides sufficient momentum to traverse the entire width.
- C. If excessive pressure is required to toggle the vacuum pump or if the pipette travel exceeds 0.5mm then the switch in the Placement Head will need adjusting. Remove the cover on the

rear side of the Placement Head by removing the two cross-slot screws. Check the action of the vacuum pipette and note the upward travel. The switch action can be adjusted by raising and lowering the bottom-securing collar. The height of the collar should be set to give a maximum Switch travel of 0.5mm.

VIII. TROUBLESHOOTING

- A. **PROBLEM:** Arm Assembly exhibits excessive play and/or square extrusion becomes displaced out of the rollers.
CAUSE: Eccentric roller wheels require adjustment
SOLUTION: Reset the roller wheels.
- B. **PROBLEM:** The nozzle is not picking up Components.
CAUSE:
1. No vacuum at the nozzle.
 2. Vacuum pump valve does not toggle.
 3. Nozzle pump has become blocked with solder paste or tubing path has become twisted.
- SOLUTION:**
1. Check that all tubes are connected. Also ensure that vacuum path is clear from vacuum pipette to the vacuum tube.
 2. Switch in the placement head needs adjusting.
 3. Find point of blockage. Replace nozzle, pipette or tubing as necessary
- C. **PROBLEM:** The knob on Placement Head fails to provide O rotation.
CAUSE: Miniature belt has become uncoupled.
SOLUTION: Remove rear panel of Placement Head Assembly and reengage or replace miniature drive belt.

IX. OPTIONAL EQUIPMENT

XIL-1 Illumination Systems

This one of a kind option has been designed to illuminate the small working area around the pick-up probe. Unlike other types of illumination systems, XIL-1 mounts directly on the arm assembly behind the placement head and travels together with the arm to the point of pick-up (trays or feeders) and to the point of placement. The 2 lamps, which are used to minimize the shadowing, are adjustable in all directions (including z axis). This allows the user to set up the illumination tailored to his individual preference. The set-up of the XIL-1 on the arm is easy and takes no longer than 30 sec.

XIL-1 Illumination system directs the light on the center of pick-up nozzle. It moves with the arm and provides illumination at the point of a component pick-up and during the component placement on a PCB.



XCAR-1 - SMD Component Carousel (Recommended for most applications)

This valuable option is recommended for users who have significant quantities of loose parts. The XCAR-1 is mounted under the Control Console in place of the Loose Component Tray. It has 15 single-component trays and 15 bisected trays which give 45 independent storage compartments for various small parts.

For user's convenience, XCAR-1 has antistatic, semi-transparent top cover to protect the parts from Dust or misplacement during transport. It can be moved one tray at a time or several trays further in both directions.

- ESD Construction
- 15 single component trays and 15 bisected trays
- Removable component trays
- Component Carousel is a convenient storage of SMD
- Used for prototyping, low volume assembly and repair work
- Trays are easily removable

Carousel Dimensions:

Diameter	35,5" (900 mm)
Height	1,77" (45 mm)
Height with top knob	2.76" (70 mm)



XMP-302 Manual Pick and Place Systems with Dispenser

Tray Holder Assembly and Component trays

Tray Holder Assemblies XL-11 to pre-kit the parts are available. They can be stored with prepared for assembly components and quickly exchanged during assembly operation. Additional XL-11 Tray Holder can be placed on XFB-1 feeder base in place of the feeders in XMP-301, 302 and 302D Machines. To place the second XL-11 Tray Holder Assembly in XMP-300, optional XL-11B Tray Holder Base is needed. Additional single and two compartment trays are also available in packages of 15 pieces.

XL-11 - Tray holder with 10 single compartment trays

XL-11B - Tray Holder Base

XL-1/15 - Pack of 15, single compartment trays

XL-2/15 - Pack of 15, two compartment trays



XL-11 Tray holder with 10 single compartment trays



XL-1



XL-2



XL-11B

Feeders

Feeders for taped components on 8,12,16 & 24mm tape are available. These are mounted onto the feeder mounting bracket supplied with the System and have a push-fix mounting. Feeders for stick-packaged components are also available. All popular sizes can be accommodated.

XPT-8 - 8mm feeder

XPT-12 - 12mm feeder

XPT-16 - 16mm feeder

XPT-24 - 24mm feeder

XFB-1 Feeder Base (shown with feeders, which have to be ordered separately).

Extra feeder base is handy when pre-kitting the Components for the particular board. The complete feeder base with feeders can be assigned to particular assembly.

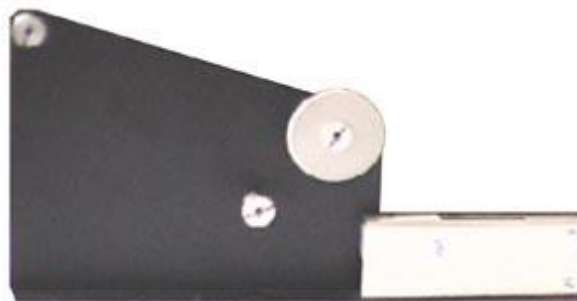

XNS-1 - Needle & Cup Set

(3 metal needles and 4 different sizes of ESD cups)

Kit Includes:

X-20SS - Metal needle

X-18-05M - Metal needle

X-14-05M - Metal needle

XV-9 ESD - ESD silicone vacuum cup 3/32" (2.4mm) diameter

XV-12 ESD - ESD silicone vacuum cup 1/8" (3.2mm) diameter

XV-25 ESD - ESD silicone vacuum cup 1/4" (6.4mm) diameter

XV-38 ESD - ESD silicone vacuum cup 3/8" (9.5mm) diameter

XCS-1 - ESD Silicone Vacuum Cup Set

(2 each of 4 sizes of ESD cups)

Kit Includes:

XV-9 ESD - 2 pcs. ESD silicone vacuum cups 3/32" (2.4mm) diameter

XV-12 ESD - 2 pcs. ESD silicone vacuum cups 1/8" (3.2mm) diameter

XV-25 ESD - 2 pcs. ESD silicone vacuum cups 1/4" (6.4mm) diameter

XV-38 ESD - 2 pcs. ESD silicone vacuum cups 3/8" (9.5mm) diameter

XNS-2 - Dispensing Tip Set

Dispensing Tips and Luer Lock tip caps

The XNS-2 (Set of 3-each of common dispensing needles and 3 syringe cups) is offered to help you select the required size. You can also order any Dispensing Needle size in packages of 25 or 100 pcs separately. (Example of P/N for 18 gauge tapered needle: for 50 pcs: XT-18-50 and for 250pcs: XT-18-250. To order different gauge just change 18 for required gauge size.).

Dispensing tips are ideal for solder paste dispensing.

Kit Includes:

3 pcs. dispensing tips - XT-14

3 pcs. dispensing tips - XT-16

3 pcs. dispensing tips - XT-18

3 pcs. dispensing tips - XT-20

3 pcs. dispensing tips - XT-22

3 pcs. Luer Lock tip caps - XLL-1

X-KAR Dispensing Tips included in the XNS-2 Dispensing Tip Set are made from high density polyethylene to include a Luer Lock hub and a taper tip. Color coding indicates tip orifice inside diameter that corresponds to the gauge. Easily cut by user when shorter tip is required.

Shaped for paste and adhesive dispensing.

XDS-1-Kit Optional Accessory for XMP-302 and XMP-302D Machines

It contains Universal Syringe Stand and XDHL-2 Syringe Head Connection Line for XDH-1 Syringe Head Assembly.

This Kit allows for use of a dispenser in XMP-302 and XMP-302D Machines by the second operator, when the first operator uses the machine in a Pick and Place Mode and does not use the dispenser.

LAMP MAGNIFIER

Combines a 22W circular fluorescent light with a 5.1" (128,8 mm) diameter, three diopter or 4.5" (114 mm) diameter, five diopter magnifying lens, housed in a sturdy metal shade. Has an internal spring arm with finger touch control tension knob to lock lamp in position. Comes with three-conductor cord and 22W circular fluorescent tube.

XLM3-115 Lamp Magnifier, dia 5.1" (128,8 mm), magnification 3x, 115V AC

XLM3-220 Lamp Magnifier, dia 5.1" (128,8 mm), magnification 3x, 220V AC

XLM5-115 Lamp Magnifier, dia 4.5" (114 mm), magnification 5x, 115V AC

XLM5-220 Lamp Magnifier, dia 4.5" (114 mm), magnification 5x, 220V AC

X. SPARE PARTS LIST FOR XMP-300 SERIES

ITEM NO.	DESCRIPTION	PART NO.
1	HAND REST	XZ-HR-1
2	FEEDER 8 mm	XPT-8
3	FEEDER 12 mm	XPT-12
4	FEEDER 16 mm	XPT-16
5	FEEDER 24 mm	XPT-24
6	LOOSE COMPONENT TRAY with 10 trays	XL-11
7	PACK OF 15 CONDUCTIVE TRAYS	XT-1/15
8	PACK OF 15 CONDUCTIVE BISECTED TRAYS	XT-1/15
9	NEEDLE / CUP SET	XNS-1
10	ESD SILICONE VACUUM CUP KIT	XCS-1
11	DISPENSING NEEDLE TIP KIT	XNS-2
12	DISPENSING HEAD	XDS-1
13	ARM ASSEMBLY, COMPLETE XMP-300/301	XZ-A301
14	ARM ASSEMBLY, COMPLETE XMP-302	XZ-A302
15	CARRIAGE ASSEMBLY, COMPLETE	XZ-CA300
16	CONTROLLER PCB, XMP-300 SERIES	XZ-CON300
17	DISPENSER CONTROLLER, XMP-302D	XZ-DIS302D
18	REPLACEMENT SWITCH, ON/OFF	XZ-S1
19	CONTROL CONSOLE TOP COVER	XZ-COV300
20	MICROSWITCH	XZ-MS1
21	DISPENSING TAPERED NEEDLE, 14G (25)	XT-14-25
22	DISPENSING TAPERED NEEDLE, 14G (100)	XT-14-100
23	DISPENSING TAPERED NEEDLE, 16G (25)	XT-16-25
24	DISPENSING TAPERED NEEDLE, 16G (100)	XT-16-100
25	SYRINGE MOUNTING ADAPTOR	XZ-SMA1
26	DISPENSER TIME SET KNOB	XZ-KN1
27	AIR GAUGE	XZ-AG1
28	AIR REGULATOR	XZ-AR1
29	VACUUM PUMP	XZ-VP1
30	PIPETTE WITH SET SCREW	XZ-PP1
31	TRANSFORMER 100/115V	XZ-TR1
32	TRANSFORMER 230V	XZ-TR2
33	ESD GROUNDING WIRE	AS3-B
34	WIRELESS WRIST STRAP	A-ML-301A



BOKAR International
 650 Scranton Pocono Hwy.,
 Covington Twp. PA 18444, USA

Tel: (570) 842-2812 Fax: (570) 842-4290

E-mail: bokar@bokar.com

www.bokar.com

US Master Distributor: www.bomir.com