



INSTRUCTION MANUAL

XK Series

Tool Stands for Top Hot Air Tool Precision Positioning and Adjustment

- XK-4 - Tool Stands with fine X-Y positioning, rotation and up/down Z-axis movement**
- XK-3 - Tool Stands with precise rotation and up/down Z-axis movement**
- XK-2 - Tool Stands with up/down Z-axis movement (dual knob)**
- XK-1 - Tool Stands with up/down Z-axis movement (right handed knob)**

Note: When the P/N has an additional pre-fix (XK-2-OK) it means that the clamp for Hot Air Tool will not fit X-KAR Hot Air Tools series XHT but was made to fit other manufacturers hand piece. Prefix OK means Metcal/OK Tool and prefix P means PACE Tool.

P/N X-DOC126
Sep-2019
Rev. C

650 Scranton Pocono Hwy
Covington Twp, PA 18444, USA
Tel: (570) 842-2812 E-Mail: bokar@bokar.com
www.bokar.com, www.SMT-tool.com, www.No-Stat.com,
www.ESDmeters.com, www.SMTreballing.net,
www.FineRework.com, www.X-Reflow306.com
www.X-1003.com, www.ZeroCharge.net



XK Series Precision Tool Stands

TABLE OF CONTENTS

	PAGE
I. INTRODUCTION	2
II. SAFETY	3
III. PACKAGING	4
IV. UNPACKING	4
V. GENERAL INFORMATION	4
VI. SET-UP AND INSTALLATION	5
VII. SYSTEM DESCRIPTION and APPLICATION	6
VIII. RECOMMENDED EQUIPMENT for use with XK-Series Stands	8

I. INTRODUCTION

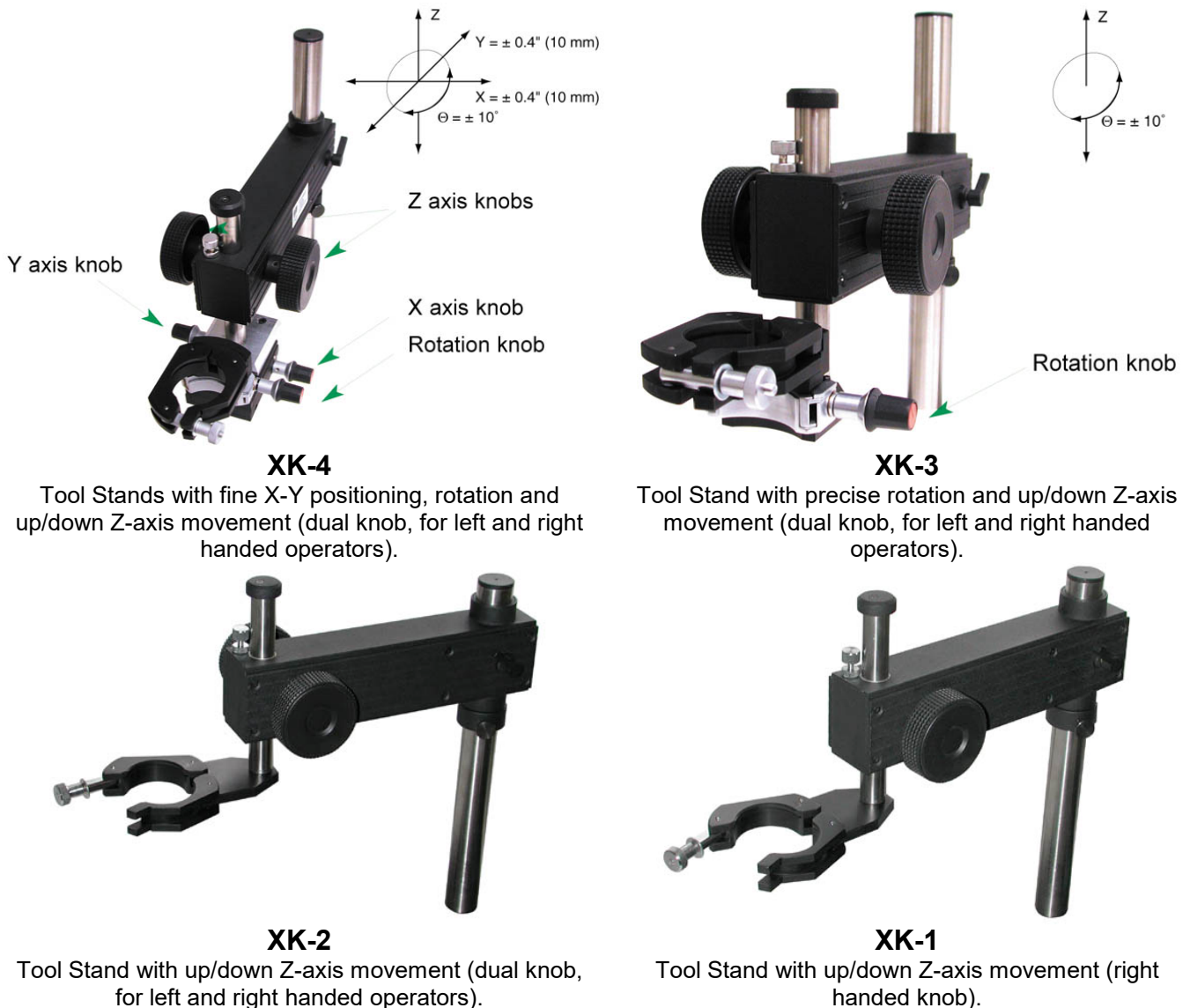

FIG. 1 VIEW OF THE SYSTEMS

XK-Series Tool Stands with adjustable Z-Axis Control and Column are designed to be mounted at the back of a top plate of an SMT-ServiCE, X-1000 Series Under Board Heaters or XS-2 ESD Base. The stand holds an XHT Series Hot Air Tool in a vertical position for precise component removal and installation operations. The hot air tool is held

XK-Series Precision Tool Stands

vertical to the work platform of a base and bottom edges of any nozzle mounted on the tool are horizontal to a PCB, which is in a board holder placed on the work platform.

Simply rotate a Vertical Control Knob to raise or lower an XHT Series Hot Air Tool with a nozzle.

An XK-3 Tool Stand will additionally allow for rotation of the Hot Air Tool and a nozzle by 10 degrees, clockwise and anticlockwise.

An XK-4 Tool Stand will additionally allow for rotation of the Hot Air Tool and a nozzle by 10 degrees, clockwise and anticlockwise and fine X-Y positioning of the Hot Air Tool and a nozzle by ± 0.4 " (± 10 mm).

II. SAFETY

The purpose of this "SAFETY" section is to inform the users of the heading guidelines used in this manual to indicate special Notes, Cautions, Warnings or Dangers. Also included are precautions, which must be observed when operating or servicing this product.

These "NOTES", "CAUTIONS", "WARNINGS" and "DANGERS" are inserted in this manual whenever deemed necessary. They appear in a blocked off form with outline and a shaded background to highlight the information as shown below.

NOTE
XX

NOTE

Used to indicate a statement of company recommendation or policy. The message may relate directly or indirectly to the safety of personnel or protection of property. NOTE is not associated directly with a hazard or hazardous situation and is not used in place of "CAUTION", "WARNING" or "DANGER".

CAUTION

Used to indicate a hazardous situation, which may result in minor or moderate injury. May also be used to alert personnel to conditions, procedures and practices which, if not observed, could result in damage to or destruction of the product or other equipment.

WARNING

Used to define additional information, that if not closely followed may result in serious damage to equipment and represent a potential for serious personnel injury.

DANGER

Defines additional information, that if not closely followed may result in severe personnel injury or death. Danger is not used for property damage unless personal injury risk is present.

PRECAUTIONS

The following are general safety precautions, which personnel must understand and follow when using or servicing this product. These precautions may or may not be included elsewhere in this manual.

CAUTIONS

1. Utilize all standard electrical safety precautions when using this or any other electrical equipment.
2. Always use this system in a well-ventilated area. A fume extraction system (such as those available from XTRACTOR) is highly recommended to protect personnel from solder flux fumes.
3. Exercise proper precautions when using chemicals (e.g., solder paste). Refer to the Material Safety Data Sheet (MSDS) supplied with each chemical and adhere to all safety precautions recommended by the manufacturer.

DANGER

POTENTIAL SHOCK HAZARD – Only qualified service personnel should perform all repairs made on this product. Line voltage parts will be exposed when equipment is disassembled. Service personnel must avoid contact with these parts when troubleshooting.

NOTES

To insure continued peak performance, use genuine Bokar replacement parts.

III. PACKAGING

The packing box contains as follows:

Model	
XK-1	<ul style="list-style-type: none"> • XK-1 Tool Stand, a column and a retaining ring. • Manual • Guarantee card
XK-2	<ul style="list-style-type: none"> • XK-2 Tool Stand, a column and a retaining ring. • Manual • Guarantee card
XK-3	<ul style="list-style-type: none"> • XK-3 Tool Stand, a column and a retaining ring. • Manual • Guarantee card
XK-4	<ul style="list-style-type: none"> • XK-4 Tool Stand, a column and a retaining ring. • Manual • Guarantee card

IV. UNPACKING

Prior to use of the system, please check if the system is complete. Should you notice that any items are missing, please notify us, giving the details of model number, voltage, date of purchase, where purchased and what is missing. Missing items must be reported within 7 days from the date of purchase.

WARNING
When unpacking, please be careful and read the manual prior to use the system.

V. GENERAL INFORMATION

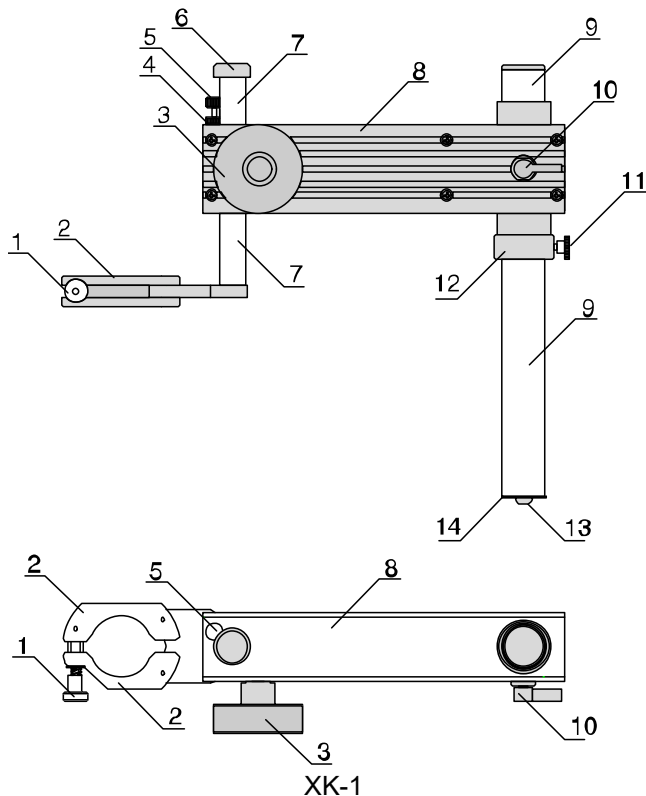

1. Clam shell Nut
2. Clam shell holding XHT Series Hot Air Tool
3. Vertical Motion Control Knob
4. Locking nut
5. Lower limit adjustment knob
6. End cup
7. Vertical slide
8. Housing
9. Main support column
10. Arm Rotation blocking nut
11. Height adjustment support
12. Height adjustment support fastening knob
13. Mounting screw
14. Washer

XK-Series Precision Tool Stands

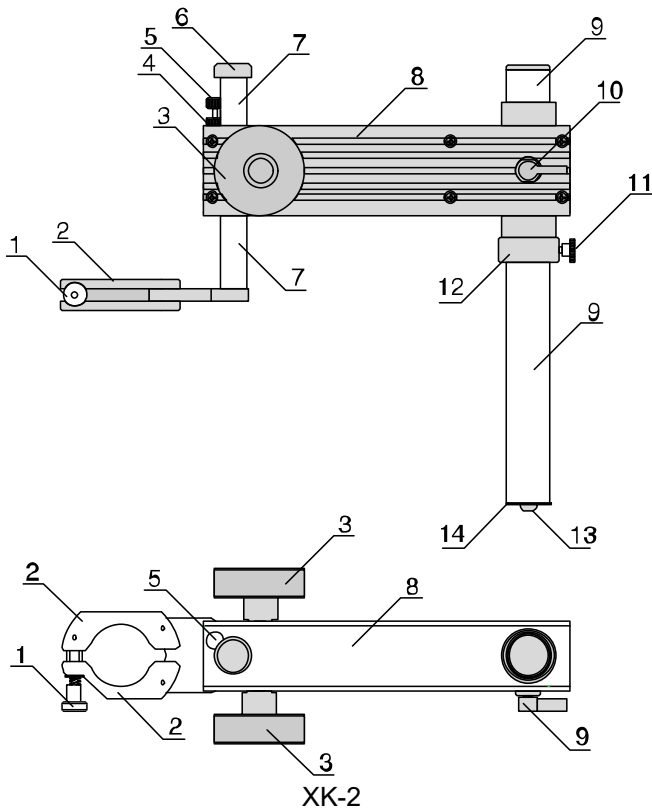

1. Clam shell Nut
2. Clam shell holding XHT Series Hot Air Tool
3. Vertical Motion Control Knob
4. Locking nut
5. Lower limit adjustment knob
6. End cup
7. Vertical slide
8. Housing
9. Main support column
10. Arm Rotation blocking nut
11. Height adjustment support
12. Height adjustment support fastening knob
13. Mounting screw
14. Washer

VI. SET-UP AND INSTALLATION

Installation of XK-Series Precision Tool Holders on SMT-ServiCE or X-1000 Pre-heaters

1. Unscrew the screw (13) from the column (9) by using hex driver and remove the washer (14).
2. Unscrew the set screw of the column holder at the back side of the base of SMT-ServiCE or X-1000 by using hex key.
3. Insert the column in the hole of the column holder. Insert the washer (14) on the screw (13) and tighten the column to the bottom side of the SMT-ServiCE or X-1000.
4. Fasten the set screw of the column holder.
5. Insert the height adjustment support (11) on the column and fasten knob (12) to secure the ring (11) on the column.
6. Insert the arm (8) with on the column and fasten arm rotation blocking nut (10) to fix the arm in desired position.

The XK Series Precision Tool Stand is ready to use.

Installation of XK-Series Precision Tool Stand on XS-2 Base is very similar.

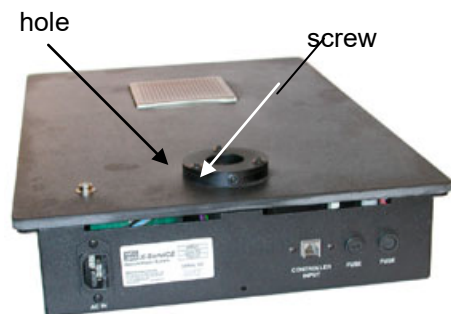

Rear view of SMT-ServiCE / X-1000 Bases



XK-2 installed on SMT-ServiCE / X-1001
Other XK-Holders install in similar way.

VII. SYSTEM DESCRIPTION and APPLICATION

Installation the XHT Series Hot Air Tool into XK Holders



1. Turn the nut clockwise several turns to release the arms fasten XHT Series Tool (2). Spread the arms fasten XHT Series Tool.

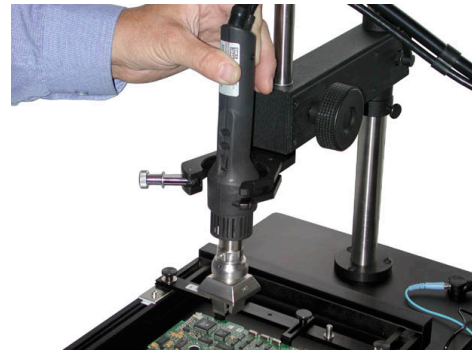

2. Place the XHT Series Tool straight in vertical position inside the clamp, matching clamp profile to the one of the handle.

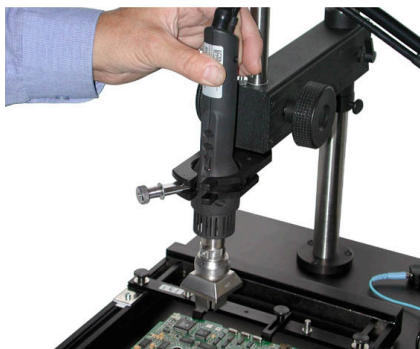

3. Close the clamp and fasten the tool

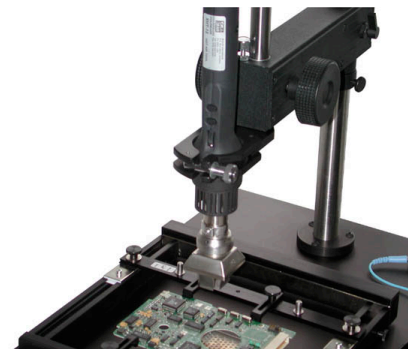

4. Tighten the nut turning it clockwise.

Using the XHT Series Hot Air Tool whit XK-1 / XK-2



Loosen nut and turn clockwise distance screw



Position distance of Nozzle-to-PCB



Fasten protected nut

The XHT Series Hot Air Tool can be easily raised or lowered using either of Height Adjustment Knobs (only XK-2, XK-1 has only one).

To provide repeatable clearance of an attached nozzle assembly relative the surface of PCB assembly (Nozzle to PCB clearance), do the following:

1. Loosen the protected nut (4) and turn clockwise distance screw (5) to the end.
2. Lower the XHT Series Hot Air Tool to the desired distance of Nozzle-to-PCB clearance using the height adjustment knobs (3).

XK-Series Precision Tool Stands

3. Ensure contact between the distance screw and protected hoop (6) by turn counterclockwise distance screw.
4. Raised the XHT Series Hot Air Tool using the height adjustment knobs and fasten the protected nut.

Using the XHT Series Hot Air Tool whit XK-3

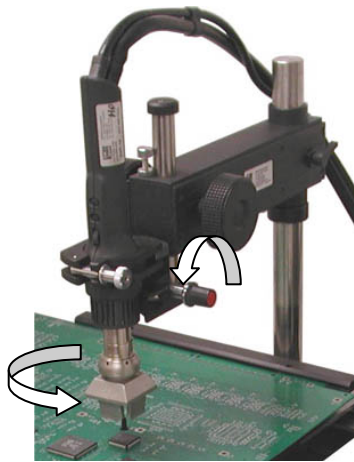

Turn the Knob clockwise to rotate the nozzle clockwise and counterclockwise to rotate the nozzle counterclockwise

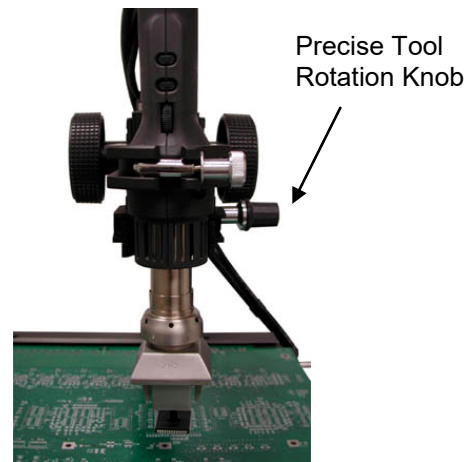

The XHT Series Hot Air Tool can be easily raised or lowered using either of Height Adjustment Knobs. XK-3 provides additional XHT Series Hot Air Tool precise rotation clockwise and counterclockwise by 10 degrees. To provide repeatable clearance of an attached nozzle assembly relative the surface of PCB assembly (Nozzle to PCB clearance), do the following the same as it is described above (Using the XHT Series Hot Air Tool whit XK-1 / XK-2).

The Precision Tool Rotation Knob provides precise rotation as follows:

1. Turn left knob rotate clockwise Hot Air Tool with Nozzle
2. Turn right knob rotate counterclockwise Hot Air Tool with Nozzle.

Using the XHT Series Hot Air Tool whit XK-4

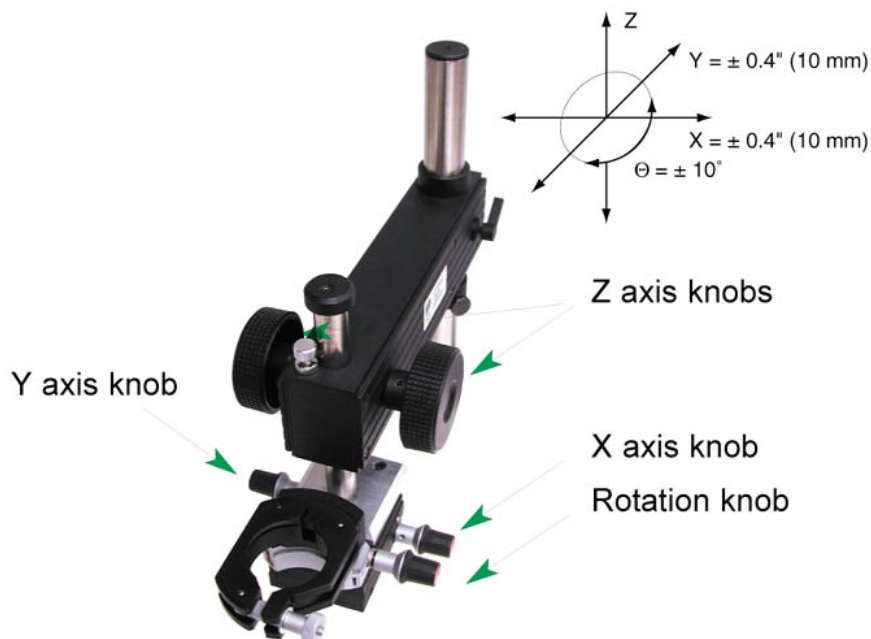

The XHT Series Hot Air Tool can be easily raised or lowered using either of Height Adjustment Knobs. XK-4 provides additional XHT Series Hot Air Tool precise rotation clockwise and counterclockwise by 10 degrees and fine X-Y positioning of the Hot Air Tool and a nozzle by $\pm 0.4''$ (± 10 mm). To provide repeatable clearance of an attached nozzle assembly relative the surface of PCB assembly (Nozzle to PCB clearance), do the following the same as it is described above (Using the XHT Series Hot Air Tool whit XK-1 / XK-2).

XK-Series Precision Tool Stands

The Precision Tool Rotation Knob provides precise rotation as follows:

1. Turn left knob rotate clockwise Hot Air Tool with Nozzle
2. Turn right knob rotate counterclockwise Hot Air Tool with Nozzle.
3. The X-Y positioning knob provides fine X-Y positioning as follows:
4. Turn left or right X-axis knob move in X-axis Hot Air Tool with Nozzle
5. Turn left or right Y-axis knob move in Y-axis Hot Air Tool with Nozzle.

VIII. RECOMMENDED EQUIPMENT for use with XK-Series Stands

1. **X-1000** or **X-1000S** Convection Pre-heater



2. **X-1001** Digital Convection Pre-heater



3. **X-10001s** Small Area Digital Convection Pre-heater



4. **SMT-ServiCE** Digital SMT Rework/Repair Unit with integrated Preheater
SMT Rework/Repair Unit designed to allow a novice to Rework or Repair complicated SMT, multi-layer PCB's quickly, without a danger of the damage to the board or components.



5. **XU-5** Open Frame Board Holder with X-Y micrometer positioning for PCB fine adjustment.



6. **XU-1S** or **XU-1** Retractable Board Holder
(Maximum board size 12" (305mm) x open end.)

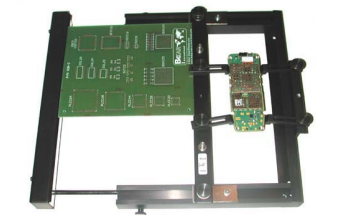

7. **XU-Mini** Irregular Shape PCB Holder (Will handle boards up to 10" wide).

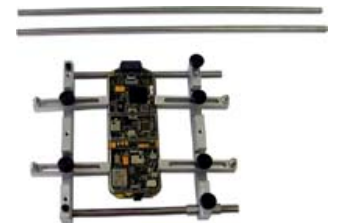

8. **XCBH-1** Board Holder for Cellular Phone Boards

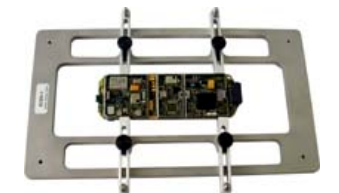

XK-Series Precision Tool Stands

9. **XU-2** Large Size Board Holder
(Maximum board size 14" (356mm) x open end.
10. **XU-3** Extra Large Size Board Holder
(Maximum board size 21" (533mm) x open end.



BOKAR International
650 Scranton Pocono Hwy
Covington Twp., PA 18444, USA

Tel: (570) 842-2812 Fax: (570) 842-4290

E-mail: bokar@bokar.com

www.bokar.com

US Master Distributor: www.bomir.com